

Differential Current Sensor with tripping characteristic acc. to the partly combined standards IEC62955:2018 and UL2231-2 Ed.2

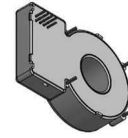

Date: 16.11.2022

K-No.:30579

Customer: Standard type

Page 1 of 7

Description

- Fluxgate current sensor with toroidal core
- PCB mounting

Characteristics

- Excellent accuracy
- Switching open-collector outputs
- Compact design

Applications

Mainly used for stationary and mobile applications:

- Wallbox
- Personnel Protection Systems for EV acc. to UL2231

Patents: EP2571128 / US9397494 / CN103001175 // EP2813856

Electrical data – Ratings

		min.	typ.	max.	Unit
I_P	Primary rated current (1phase / 3phase)			80 / 40	A
$I_{\Delta N1}$	Rated residual fault current 1		6		mA dc
$I_{\Delta N2}$	Rated residual fault current 2		20		mA rms
$I_{\Delta N1, tolerance}$	Trip tolerance 1 (PIN X6-OUT)	4	5	6	mA dc
$I_{\Delta N2, tolerance}$	Trip tolerance 2 (PIN X20-OUT)	14		20 ⁽¹⁾ / 70 ⁽²⁾	mA rms
$S_{PWM-OUT}$	Scaling factor of the dc component (for monitoring purpose only!)		3.33		%/mA
$I_{ARI,1/2}$ (Fig.1)	Recovery current level for $I_{\Delta N1}$ or $I_{\Delta N2}$ (absolute value dc/rms)		2.5 / 10		mA

(1) f = rated frequency (2) f = 2kHz

Accuracy – Dynamic performance data

$I_{\Delta N,max}$	Measuring range (peak)	-300		+300	mA
X	Resolution (@ $I_{\Delta N}$, $\Theta_A = 25^\circ C$)		< 0.2		mA
t_r	Response times		According to IEC62955:2018 ⁽³⁾ According to UL2231-2 Ed.2		
f_{BW}	Frequency range	DC		2	kHz

General data

ϑ_A	Ambient operation temperature	-40		85	°C
$\vartheta_{Storage}$	Ambient storage temperature ⁽⁴⁾	-40		85	°C
m	Mass		21		g
V_{CC}	Supply voltage	4.8	5	5.2	V
I_{CC}	Supply current		33		mA rms
$S_{clear, ps}$	Clearance (primary to secondary)		not applicable if insulated cable is used ⁽⁵⁾		
$S_{creep, ps}$	Creepage (primary to secondary)		not applicable if insulated cable is used ⁽⁵⁾		
FIT	EN/IEC 61709 / SN 29500 ⁽⁶⁾		<2200		fit

⁽³⁾ Switching time of a standard relay (IEC: t = 20ms / UL: t = 10ms) is considered.

⁽⁴⁾ see VAC M-sheet 3101; storage temperature inside cardboard packaging

⁽⁵⁾ Constructed, manufactured and tested in accordance with IEC60664-1:2020

Isolated wires are preferred. If isolated primary conductors are used, the isolation coordination is according to:
Reinforced insulation, Insulation material group 1, Pollution degree 2, and overvoltage category III.

⁽⁶⁾ The results are valid under following conditions: 55°C mean component ambient temperature by continuous operation (8760h per year); Environment condition: ground mobile, no dust or harmful substances, according to IEC61709; Fit equals one failure per 10⁹ component hours.

General description of sensor function:

The Sensor is sensitive to AC and DC current and can be used for fault current detection in wallbox applications or personnel protection systems for EV. The Sensor detects DC fault current according to IEC62955:2018 and AC fault currents according to UL2231-2 Ed.2 In the event of a DC fault current, PIN 3 will change its state from a low level (GND) to high impedance state. In the event of an AC fault current, PIN 4 will change state from a low level (GND) to a high impedance state, see tab.1. Error conditions (e.g. an internal error) are signaled on PIN 1 (ERROR-OUT). The sensor only fulfills the switch-off characteristic of the IEC62955 standard (monitoring the residual current). An additional driver-circuit must be used for driving RCBO, RCCB or circuit breaker as defined in IEC62955. The sensor's outputs are limited to max. 40V/50mA!

Datum	Name	Index	Änderung
16.11.2022	SF	81	Change of typical application diagram. CN-22-157
02.06.2022	SF	81	Mistake in general description, New state in tab. 1 CN-22-115

Editor.:R&D-PD-NPI D	Designer: SF	MC-PM: BZ	Released by: SB
----------------------	--------------	-----------	-----------------

Differential Current Sensor with tripping characteristic acc. to the partly combined standards IEC62955:2018 and UL2231-2 Ed.2

Date: 16.11.2022

K-No.:30579

Customer: Standard type

Page 3 of 7

Typical application diagram:

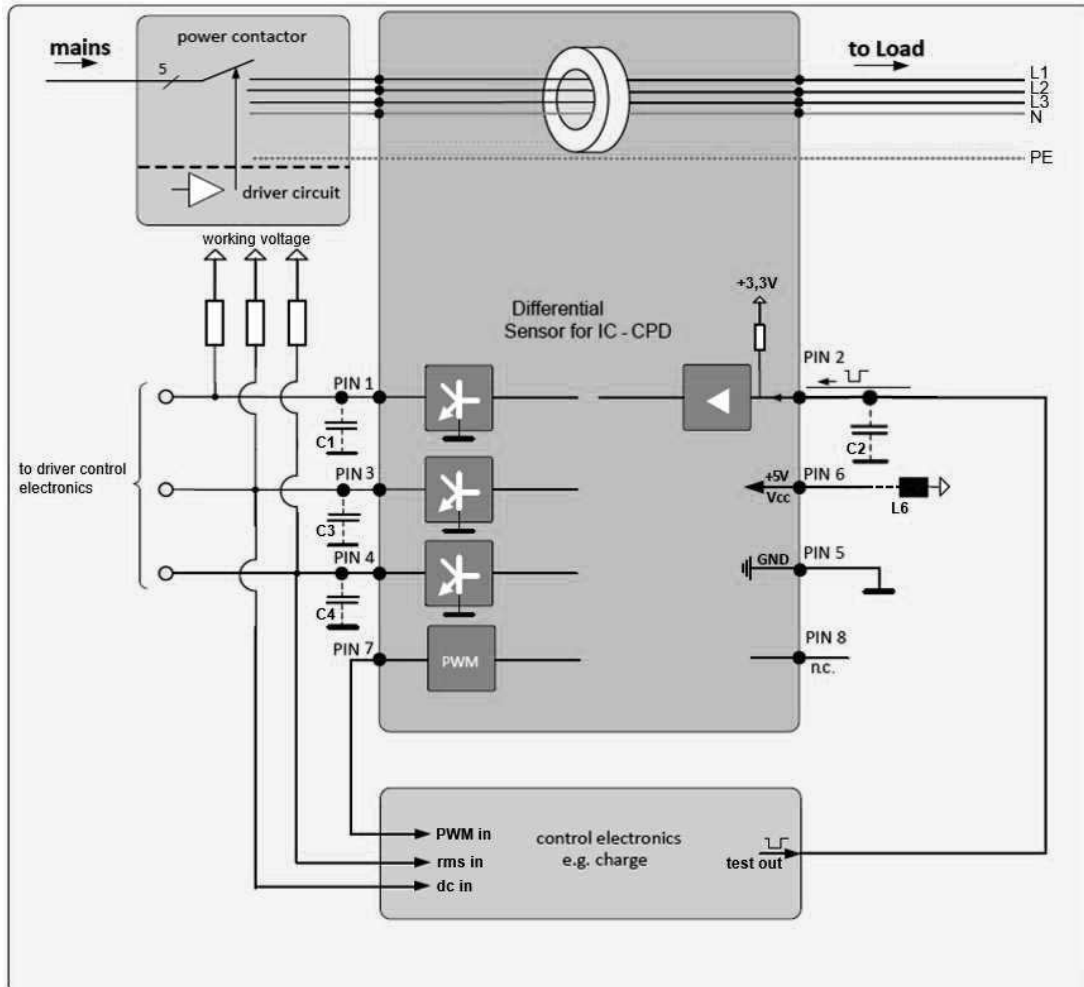

Recommended: C1, C3, C4 with 100nF to ground and C2 with 10nF to ground as optional EMC improvement.
(Components have to be placed close to the device pins)
L6 is not longer recommended for new designs, in existing layouts component L6 should be used with the following parameters:
L6: Inductance ≤220 μH; DC Resistance 1 to 5 Ω

Absolute maximung ratings⁽⁶⁾:

		Min.	Typ.	Max.	Unit
V_{CE}	Collector-emitter voltage (PINs 1, 3 and 4)			40	V
I_C	Collector current (PINs 1, 3 and 4)			50	mA
V_{CC}	Maximum supply voltage (without function)	-0.3		6	V
U_{MAX}	Maximum rated voltage of primary conductors (AC rms)			250	V
$V_{TEST-IN, low}$	TEST-IN Input Voltage, low level	0		0.6	V
$V_{TEST-IN, high}$	TEST-IN Input Voltage, high level	2.5		5	V

⁽⁶⁾Stresses above these ratings may cause permanent damage.
Exposure to these conditions for extended periods may degrade device reliability.
Functional operation of the device at these or any other conditions beyond those specified is not supported.

Differential Current Sensor with tripping characteristic acc. to the partly combined standards IEC62955:2018 and UL2231-2 Ed.2

Date: 16.11.2022

K-No.:30579

Customer: Standard type

Page 4 of 7

Final Tests: (Measurements after temperature balance of the samples at room temperature, SC=significant characteristic)

		Min.	Max.	Unit
Vcc	Supply voltage	4.9	5.1	V
Icc	Supply current	16.0	28.0	mA
TEST-IN	TEST-IN voltage	2.8	3.4	V
X6-OUT (normal)	X6-OUT voltage	0	0.6	V
X20-OUT (normal)	X20-OUT voltage	0	0.6	V
ERROR-OUT (normal)	ERROR-OUT voltage	0	0.6	V
X6-OUT (activated)	X6-OUT voltage activated @5V, 1kΩ (pull-up)*	4.9	5.1	V
X20-OUT (activated)	X20-OUT voltage activated @5V, 1kΩ (pull-up)*	4.9	5.1	V
ERROR-OUT (activated)	ERROR-OUT voltage activated @5V, 1kΩ (pull-up)*	4.9	5.1	V
TC1 (SC)	Trip current 1 – X6	4.5	5.4	mA
TC2 (SC)	Trip current 2 – X6	-5.4	-4.5	mA
TC3 (SC)	Trip current 3 – X20@60Hz	14	20	mA
PWM-OUT (frequency)	PWM-OUT frequency	7.8	8.2	kHz
PWM-OUT (duty-cycle)	PWM-OUT duty-cycle @6mA, DC	18	22	%
LV1 (SC)	Limit values of break time - X6-OUT@6mA DC	0	700	ms
LV2 (SC)	Limit values of break time – X20-OUT@20mA, 60Hz	0	1000	ms
NTC1	X6-OUT & X20-OUT@50mA,50Hz	0	0,6	V

* the maximum values of collector-emitter voltage and current see "Absolute maximum ratings"

Product Tests: The EMC product standards can only be fulfilled in the complete application system (more EMC test's can be shown if required).

	Acc. to VAC sheet M3238	passed
	Following tests differ from M3238:	
	4.5a: Damp heat, steady state. Duration: 1000h	
ESD	Air- and contact discharge; U=±2000V, R=1500Ω, C=100pF acc. to Human Body Model JESD22-A114	±2.0 kV

Differential Current Sensor with tripping characteristic acc. to the partly combined standards IEC62955:2018 and UL2231-2 Ed.2

Date: 16.11.2022

K-No.:30579

Customer: Standard type

Page 5 of 7

Requalification Tests: (replicated every year, Precondition acc. to M3238)

$\hat{U}_{W, \text{prim-sec}}$	M3064	Impulse test (1.2 μ s/50 μ s waveform) PIN 1-8 vs. insulated primary wire 5 pulse \rightarrow polarity +, 5 pulse \rightarrow polarity -	5.5	kV
U_d	M3014	Test voltage, 60s PIN 1-8 vs. insulated primary wire	1.5	kV rms
U_{PDE}	M3024	Partial discharge voltage (extinction) PIN 1-8 vs. insulated primary wire *acc. to table 24	1.2	kV rms
$U_{PD} \times 1.875$	M3024	Partial discharge voltage (extinction) PIN 1-8 vs. insulated primary wire *acc. to table 24	1.5	kV rms

* IEC 61800-5-1:2007

Other instructions:

- Temperature of the primary conductor should not exceed 105°C.
- Vcc during Test-IN function test must be in rated range.
- Housing and bobbin material UL-listed, flammability class 94V-0.
- Fall- and rise-time of Vcc: $t > 20\mu\text{s/V}$
- UL certification is still pending
- Further standards UL 2231 E file No. 488116, category FFUQ2 / FFUQ8

Figures:

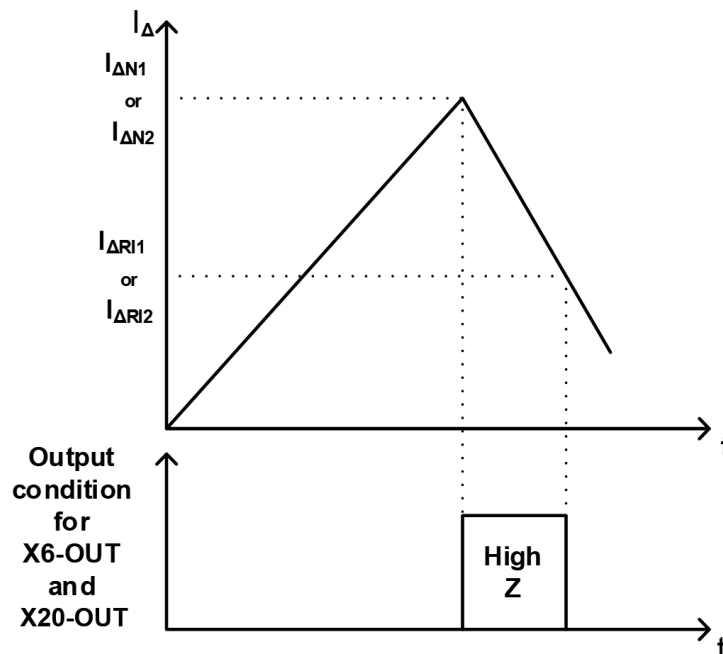
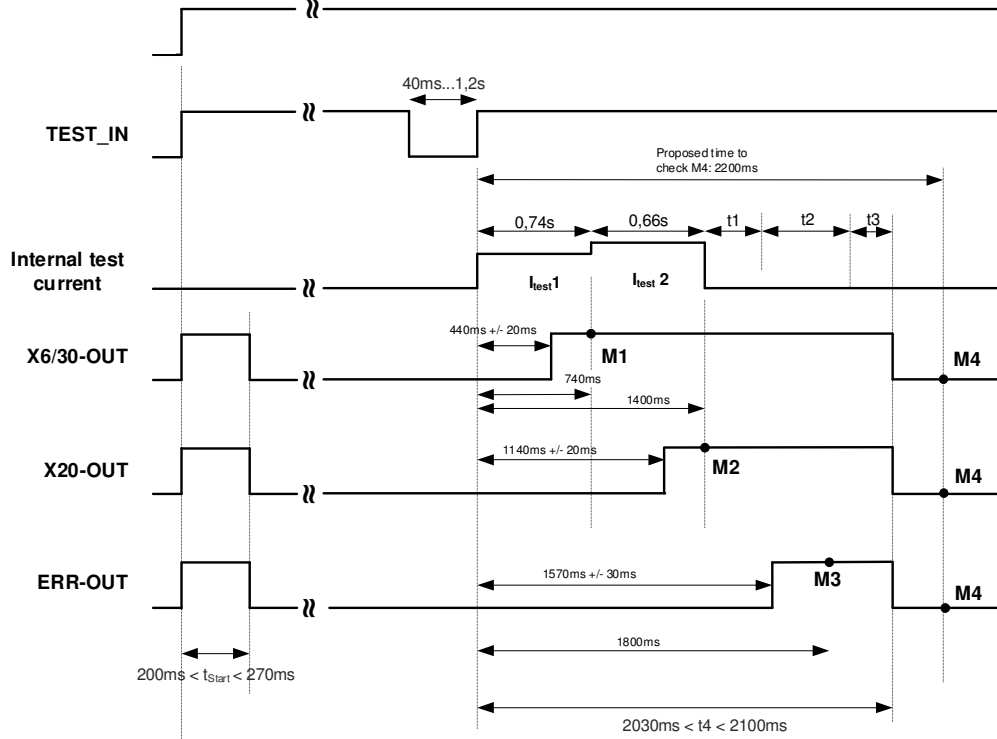

Fig. 1: Meaning of switching recovery level

If the trip-level $I_{\Delta N1}/I_{\Delta N2}$ is accomplished the corresponding output X6-OUT/X20-OUT will change its state from low-level (GND) to high impedance. Depending on the existence of the differential current I_{Δ} , the outputs X6-OUT/X20-OUT will remain in their states until I_{Δ} is below the recovery threshold $I_{\Delta R1}/I_{\Delta R2}$.



t1 = 120ms
t2 = 500ms
t3 = 10ms to 80ms

M1...M4

Check for welded contacts.
Time for offset calibration.
Time required to store the offset calibration value. Depends on the difference to the value already stored in memory.
points in time to check output levels

Fig. 2: Power-Up timing diagram

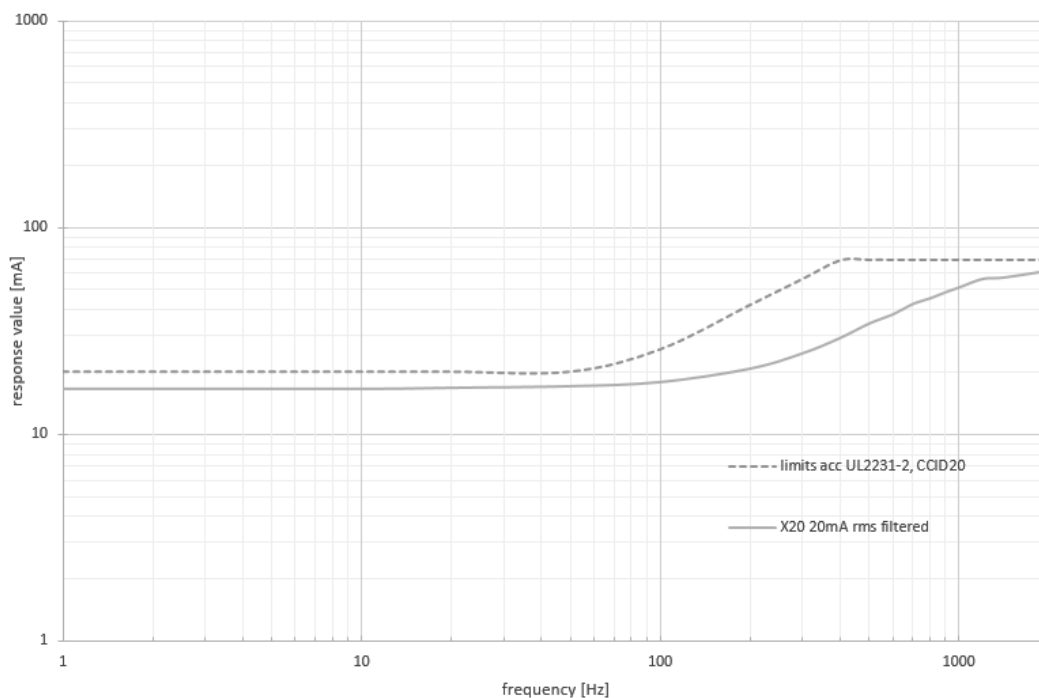

Fig. 3: UL2231 response value over frequency

Differential Current Sensor with tripping characteristic acc. to the partly combined standards IEC62955:2018 and UL2231-2 Ed.2

Date: 16.11.2022

K-No.:30579

Customer: Standard type

Page 7 of 7

X6-OUT	X20-OUT	ERROR-OUT	State
GND	GND	GND	Normal condition
High impedance	GND	GND	$I_{\Delta} \geq 6\text{mA}_{\text{DC}}$
GND	High impedance	GND	$I_{\Delta\text{N}2} \geq 20\text{mA}_{\text{rms}}$
High impedance	High impedance	GND	$I_{\Delta} \geq 6\text{mA}_{\text{DC}}$ AND $I_{\Delta\text{N}2} \geq 20\text{mA}_{\text{rms}}$
High impedance	High impedance	High impedance	Error, system fault
All other conditions not mentioned in the table are not possible. If these conditions occur, the sensor is in unknown state and describes an Error.			

Table 1: Possible output states

	6mA	60mA	200mA
Standard values acc. to IEC62955:2018	10s	0.3s	0.1s
Typical values of sensor	0.45s	0.06s	0.035s

Table 2: Maximum and typical values of break time for residual direct currents